

BRIDEX

EVA-E

Energy Meter



Product Introduction

EVA-E, complete microprocessor based, poly-phase power & energy meter is equipped with high-resolution liquid crystal display to complete its new state of the art outlook. EVA-E is a multi function power & energy meter, an ideal replacement for stand-alone kilowatt, kilowatt-hour, kilovar, kilovar-hour, kilovoltampere and kilovoltampere-hour meters in the market. It is one of the most cost effective yet function rich device with power and energy display in one concept. In addition, it will display maximum kW demand for user configurable time (15min, 30min or 60min), indicating the maximum kW consumed by the connected load in the past. We offer this solution with high accuracy class of +/-1.0% and additional features such as user selectable CT ratio settings, network configuration settings, maximum demand period & pulsing output for third party energy measurement.

Basic Features

EVA-E is designed to give average values of measured parameters at every 1 second interval. Therefore it will give almost instantaneous reading of power measurement. EVA-E can directly measure voltage up to 500VAC combined with current input from external current transformer ranging from 1A - 6000A. Equipped with large 16-digit liquid crystal display, which allow clear viewing of energy consumed at the point of installation. EVA-E will display following power parameters:

- Kilowatt (1 second average)
- Kilovar (1 second average)
- Kilovoltampere (1 second average)
- Aggregate kilowatt-hour
- Aggregate kilovar-hour
- Aggregate kilovoltampere-hour
- Maximum demand in kW (15min, 30min or 60min average)

EVA-E gives user a choice to select:

- Network configuration - single phase/ 3P3W/ 3P4W
- Current transformer ratio (1A to 6000A)
- Pulse output (1 pulse for 1kWh / 1 pulse for 10kWh)
- Pulse width (150msec)

Selection Guide

Product Code	Network Type (programmable)	Panel Cut-out	Auxiliary Supply	Communication
B-EVA-E	Single Phase / 3P3W / 3P4W	96 x 96	230VAC	Pulse output



Specifications

General

Network type (Programmable)	: Single phase, 3 phase 3 wires, 3 phase 4 wires
Accuracy & standard	: According to IEC 1036 Class 1
Ambient temperature	: 0-50 deg C
Humidity	: 0-95% non condensing

Input

Input voltage	: 0-500VAC
Input voltage tolerance	: 80-110% of Un
Burden	: < 0.2VA per phase
Overload conditions	: 1.5 x Un continuous : 4 x Un for 1 second
Input current	: 5A(6)
Input current tolerance	: 10-120%
Burden	: < 0.2VA per phase
Overload conditions	: 4 x In continuous
Frequency	: 50/60Hz
Auxiliary Supply	: 230VAC

Output (optional)

KWh pulse output	: Mercury wetted volt free relay
Pulse rate	: 1 pulse per kWh or 10kWh
Pulse duration	: 150 msec

Enclosure

Display	: 16 digit LCD display including 2 decimal places, re-settable
Dimension	: DIN 96x96x98mm
Panel mount	: via 4 corner bracket and thumb tensioning screws
Panel cutout	: 92 + 0.8mm x 92 + 0.8mm
Material	: black polycarbonate complying with UL 94VO. The cover/window is made from plexiglass 7N
Fixing	: Snap on DIN rail 35 x 7.5mm complying with DIN 50022 BS5584
Enclosure code	: Case IP50 / terminal IP 30 complying with IEC529 BS5490 DIN 40050
Terminal	: 3.5mm

Insulation

Test voltage	: 4kV RMS 50Hz for 1 min
Impulse test	: EMC 5kV transient comply with IEC801 / EN55020
HF interference test	: EHF 2.5kV 1MHz comply with IEC255-4

Ordering Format

B - **EVA-E**
 ↓ ↓
Bridex **Energy Meter**

Dimension Diagram

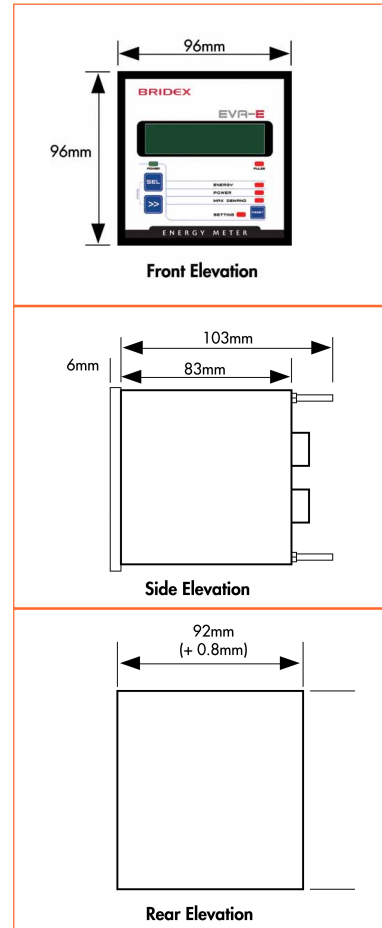

Wiring Diagram

